



Cabinets & Racks

Wall-Mounted Cabinet – Model Q



Linxcom 19" wall-mounted cabinets and racks are a cost-effective solution that is both aesthetically pleasing and durable. Designed to be installed in data centres, equipment rooms and office environments to mount telecommunication, data communication, security, broadcasting and other electronic equipment.

Features & Benefits

- Available in a variety of heights and depths
- Available in grey or black - more colours available
- Tempered glass 200° swing front door with lock
- Feet and castors can be provided for floor-standing option
- Adjustable front and rear mounting rails
- 600mm wide body
- Quick removable side doors, optional key locks if required
- Vented top and bottom panels enabling ventilation and reliable operation
- Compatible with various 19" accessories
- Maximum 50kgs UDL loading capacity

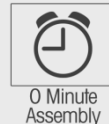

Below we have our standard stock sizes for height, widths and depths, but we also offer custom-built cabinets. If you require a specification which is not specified, then contact us and we can assist you.

Available Configurations

Capacity (U)	Height (mm)	Widths (mm)	Depths (mm)	Colours
6	310	540	600	Black, Grey
9	445	540	600	Black, Grey
12	580	540	600	Black, Grey
15	710	540	600	Black, Grey

Technical Specifications

Part	Material	Surface
Frame	SPCC Cold-Rolled Steel 1.0mm	Powder Coated/Vented Front & Sides
Side Panel	SPCC Cold-Rolled Steel 1.0mm	Powder Coated
Front Door	Toughened Glass 5mm	
Rail	SPCC Cold-Rolled Steel 1.0mm	Powder Coated/Vented (Optional)



Cabinets & Racks

Wall-Mounted Cabinet – Model Q

Technical Drawings

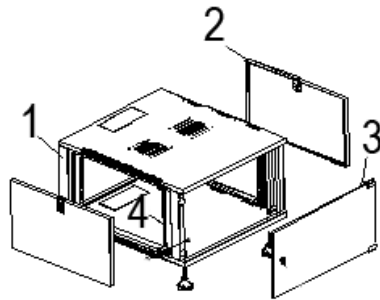

1	Frame
2	Side Panel
3	Front Door
4	Rail

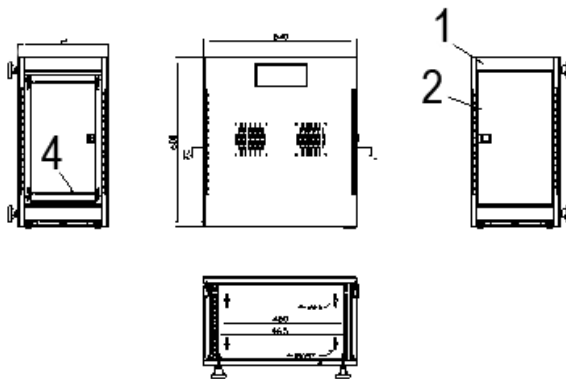

Ordering Information

Using the available configurations amend/create product codes using the formula below.

Linxcom		Colour		Depth	
Linxcom	LXM	Black	BLK	600mm	6
		Grey	GRY		
LXM	Q	BLK	5	6	12
Model		Width		U Capacity (Height)	
Model Q	Q	540mm	5	15U (710mm)	15
				12U (580mm)	12
				9U (445mm)	09
				6U (310mm)	06

Example: **LXMQLK5612** - Linxcom Model Q 12U 540*600mm Black Wall Cabinet

For any queries, please contact the Linxcom team using the details below.