



Cabinets & Racks

Floor Cabinets – Model E



Linxcom 19" floor-standing cabinets and racks are a cost-effective solution that is both aesthetically pleasing and durable. Designed to be installed in data centres, equipment rooms and office environments to mount telecommunication, data communication, security, broadcasting and other electronic equipment.

Features & Benefits

- Medium duty cabinet of durable modular construction
- Various 200° swing doors available, including: glass, punched, horizontal, double vertical
- Lockable and removable side panels
- Adjustable/lockable cable entries at the top and bottom
- U-marked frames can be removed and adjusted to requirement
- Mounts for hanging/suspending cabinet
- Comes complete with fan tray, fans and earthing screws
- Available in grey or black - more colours also available
- Linkable cabinet
- Various accessories available, including fan trays, PDUs, cable management panels and more
- Maximum 1000kgs UDL loading capacity



30 Minute Assembly



2 Person Assembly



Available Flat-Packed



IP Rating Available



Available Ready-Built



1000kgs UDL Capacity

Below we have our standard stock sizes for height, widths and depths, but we also offer custom-built cabinets. If you require a specification which is not specified, then contact us and we can assist you.

Available Configurations

Capacity (U)	Height (mm)	Widths (mm)	Depths (mm)	Colours
47	2220	600, 800	600, 800, 1000	Black, Grey
42	1990	600, 800	600, 800, 1000	Black, Grey
37	1760	600, 800	600, 800, 1000	Black, Grey



Cabinets & Racks

Floor Cabinets – Model E

Technical Specifications

Part	Material	Surface
Flying Rings	Steel	Plated White Zinc
Top Cover	SPCC Cold-Rolled Steel 1.5mm	Powder Coated
Fan Tray	SPCC Cold-Rolled Steel 1.0mm	Powder Coated
Frame	SPCC Cold-Rolled Steel 1.5mm	Powder Coated
Mounting Profile	SPCC Cold-Rolled Steel 2.0mm	Plated White Zinc
Mounting Angle	SPCC Cold-Rolled Steel 2.0mm	Plated White Zinc
Side Panel	SPCC Cold-Rolled Steel 1.5mm	Powder Coated/Vented
Left Rear Door	SPCC Cold-Rolled Steel 1.2mm	Powder Coated/Punched
Right Rear Door	SPCC Cold-Rolled Steel 1.2mm	Powder Coated/Punched
Tray	SPCC Cold-Rolled Steel 2.0mm	Powder Coated
Front Door	SPCC Cold-Rolled Steel 1.5mm Toughened Glass (Optional)	Powder Coated/Punched

Technical Drawings

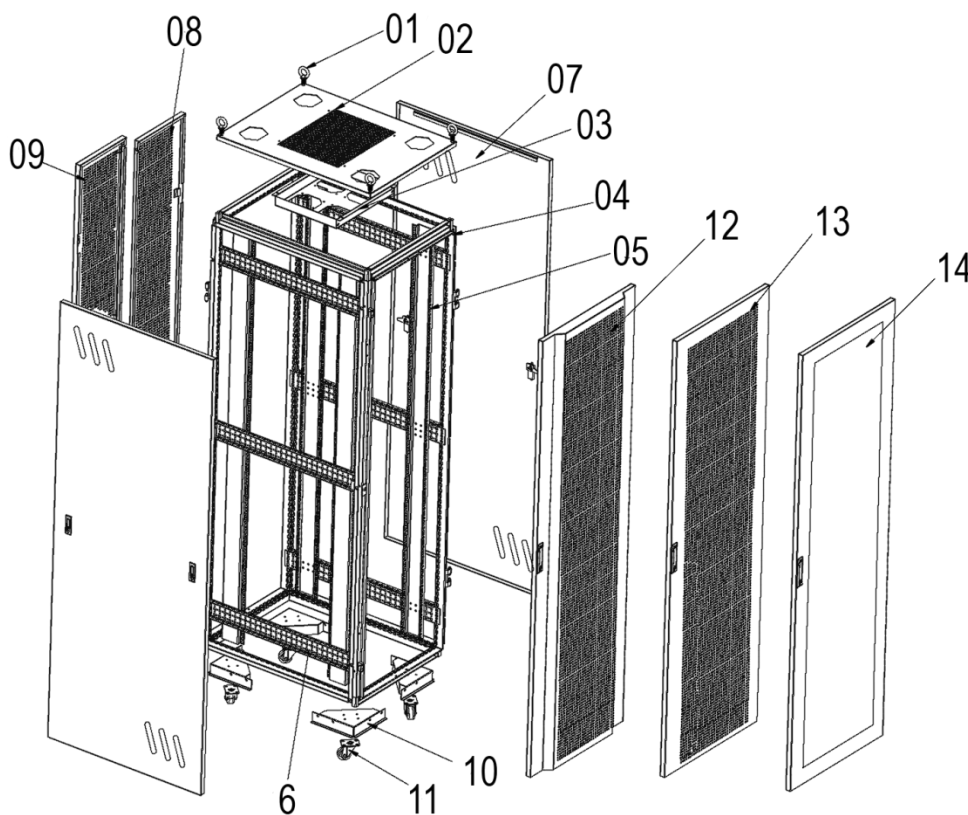

1	Flying Rings
2	Top Cover
3	Fan Tray(Optional)
4	Frame
5	Mounting Profile
6	Mounting Angle
7	Side Panel
8	Left Rear Door
9	Right Rear Door
10	Tray
11	Heavy Duty Castor
12	TD Front Door
13	Ventilation Plate Front Door
14	Toughened Glass Front Door



Cabinets & Racks

Floor Cabinets – Model E

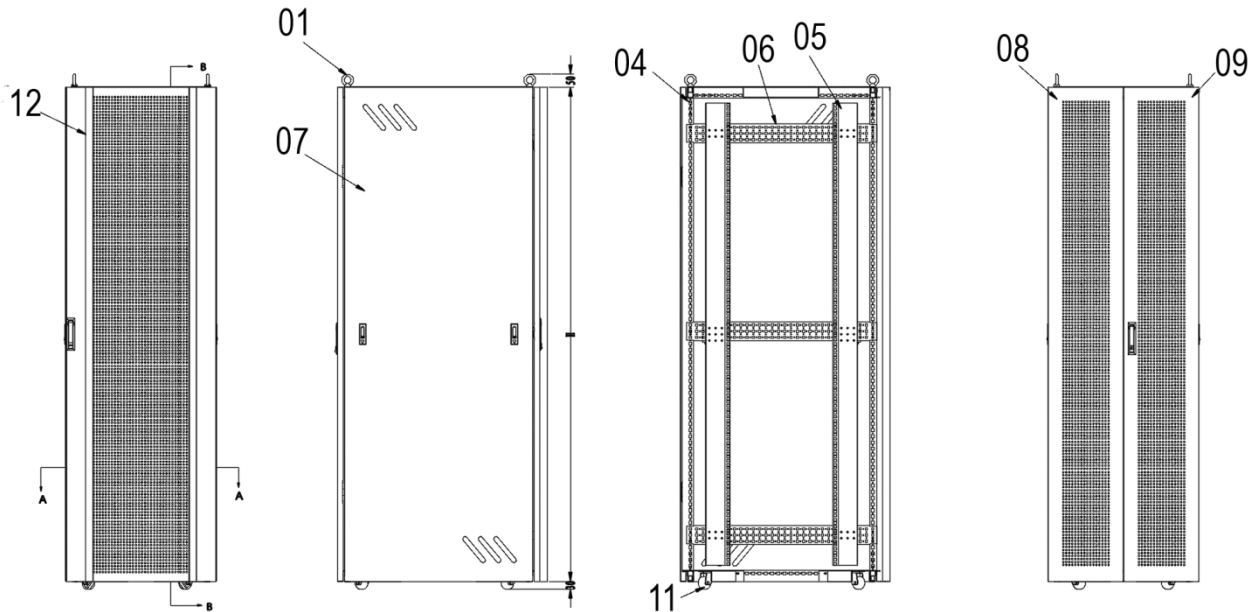

Ordering Information

Using the available configurations amend/create product codes using the formula below.

Linxcom		Colour		Depth	
Linxcom	LXM	Black	BLK	800mm	8
		Grey	GRY	900mm	9
				1000mm	1
LXM	E	GRY	6	8	37
Model		Width		U Capacity (Height)	
Model E	E	600mm	6	47U (2220mm)	47
		800mm	8	42U (2000mm)	42
		(Only for 42U or 47U)		37U (1800mm)	37

Example: **LXMEGRY6837** - Linxcom Model E 37U 600*800mm Grey Floor Cabinet

For any queries, please contact the Linxcom team using the details below.